

# **NHRC**

**REPEATER CONTROLLERS**

# NHRC-3 + User Guide

Software Version: 1.10

User Guide Version: 2005-Sep-27

# Copyright Notice

Copyright © 2001, 2002, 2003, 2004, 2005 by NHRC LLC

This document contains proprietary information which is the confidential property of NHRC LLC.

No part of this document may be used or reproduced, by any means, for any purpose, without the expressed written consent of NHRC LLC.

No part of this document should be considered to be specifications for the proper or correct operation of the NHRC-3+ Repeater Controller. In no way will NHRC LLC be liable for direct or indirect damages to the controller or attached equipment.

Printed in the U.S.A.

# Thank You!

Thank you for purchasing the NHRC-3+ Repeater Controller. This controller has been designed using the very latest state-of-the-art technology. Please review this manual carefully before putting your controller into operation.

This manual represents a very large documentation effort. Your comments are important to us. If you find an error or find any passages that are not clearly understandable, we would like to hear about it. Please send your comments to ***software@nhrc.net***.

Support for the controller is available by email or telephone. Please direct software-related questions via email to ***software@nhrc.net***. Please direct hardware-related questions via email to ***hardware@nhrc.net***. Your question(s) will be answered promptly.

Questions of a more urgent nature can be answered by telephone support. Telephone support is available Monday through Friday, from 6 PM until 10 PM, Eastern time.



# Table of Contents

<b>1. INTRODUCTION .....</b>	<b>1</b>
1.1 SENDING COMMANDS.....	2
1.2 ID MESSAGES.....	2
1.3 “UNLOCKED MODE” .....	3
<b>2. ELECTRICAL CONNECTIONS .....</b>	<b>4</b>
2.1 INPUT AND OUTPUT SIGNAL LEVELS .....	4
2.2 J2: CONTROLLER/REPEATER INTERFACE .....	5
2.3 J1: NHRC-DAD INTERFACE.....	5
2.4 JTS64: TS-64 INTERFACE .....	6
2.5 J3: EXPANSION CONNECTOR.....	7
2.5.1 <i>Courtesy Tone Selection</i> .....	7
2.5.2 <i>Digital Output Ports</i> .....	7
2.5.3 <i>Power and Ground connectors</i> .....	8
2.6 AUDIO LEVEL ADJUSTMENT .....	9
2.7 THE LED INDICATORS.....	11
<b>3. PROGRAMMING THE CONTROLLER.....</b>	<b>12</b>
3.1 QUICK SETUP.....	12
3.2 INITIALIZING THE CONTROLLER.....	14
3.3 *0: UNLOCKED MODE CONTROL OPERATOR ACCESS.....	15
3.3.1 <i>Set Control Operator Switches</i> .....	15
3.4 *1: SAVE SETUP.....	16
3.4.1 <i>Save configuration setup</i> .....	16
3.5 *2: PROGRAM COMMAND PREFIXES .....	17
3.5.1 <i>Set command prefix</i> .....	18
3.6 *3: SET TIMERS.....	19
3.6.1 <i>Program a timer</i> .....	20
3.7 *4: (RESERVED FOR NHRC).....	21
3.8 *5: (RESERVED FOR NHRC).....	21
3.9 *6: (RESERVED FOR NHRC).....	21
3.10 *7: PROGRAM CW AND BEEP MESSAGES .....	22
3.10.1 <i>Program a CW ID</i> .....	22
3.10.2 <i>Program or play courtesy tones</i> .....	23
3.11 *8: PLAY/RECORD VOICE TRACKS .....	24
3.11.1 <i>Play a message</i> .....	24
3.11.2 <i>Record a message</i> .....	25
3.12 *9: (RESERVED FOR NHRC).....	25
3.13 **: RESET CONTROLLER.....	25
<b>4. CONTROL OPERATOR COMMANDS.....</b>	<b>26</b>
4.1 GROUP 0 SWITCHES: REPEATER CONTROL .....	27
4.2 GROUP 1 SWITCHES: MORE REPEATER CONTROL .....	29
4.3 GROUP 2 SWITCHES: VOICE ID AND MISC. CONTROL .....	31
4.4 GROUP 3 SWITCHES: RESERVED FOR NHRC .....	32
4.5 GROUP 4 SWITCHES: EXPANSION OUTPUTS MODE CONTROL.....	34
4.6 GROUP 5 SWITCHES: EXPANSION OUTPUTS CONTROL.....	35
4.7 GROUP 6 SWITCHES: PROGRAMMING WRITE PROTECT .....	36
4.8 GROUP 7 SWITCHES: CONTROL OPERATOR GROUP ACCESS .....	37
<b>5. USER COMMANDS.....</b>	<b>38</b>
5.1 DTMF ACCESS.....	38
5.2 DIGITAL OUTPUT CONTROL.....	39
5.3 LOAD SAVED SETUP .....	40
<b>6. APPENDICES.....</b>	<b>41</b>
6.1 FACTORY DEFAULTS.....	41

6.1.1	<i>Default Command Prefixes Table</i> .....	41
6.1.2	<i>Timer Defaults Table</i> .....	42
6.1.3	<i>Courtesy Tone Component Tones Table</i> .....	43
6.1.4	<i>CW (“Morse Code”) Character Table</i> .....	44
6.2	<b>CONTROL OPERATOR CONTROLS</b> .....	45
6.2.1	<i>Control Operator Group 0 (Repeater Control) Operations Table</i> .....	45
6.2.2	<i>Control Operator Group 1 (Repeater Control II) Operations Table</i> .....	45
6.2.3	<i>Control Operator Group 2 (Voice and Tail ID Messages) Operations Table</i> .....	46
6.2.4	<i>Control Operator Group 3 (Reserved for NHRC)</i> .....	46
6.2.5	<i>Control Operator Group 4 (Digital Output Mode Control) Operations Table</i> .....	47
6.2.6	<i>Control Operator Group 5 (Digital Output Control) Operations Table</i> .....	47
6.2.7	<i>Control Operator Group 6 (Programming Write Protect) Operations Table</i> .....	48
6.2.8	<i>Control Operator Group 7 (Control Operator Group Access) Operations Table</i> .....	48
6.3	<b>TERMINOLOGY AND ABBREVIATIONS</b> .....	49
<b>7.</b>	<b>CIRCUIT BOARD</b> .....	<b>50</b>
7.1	INTERCONNECTIONS.....	50
7.2	JUMPERS.....	50
7.3	NHRC-3+ DETAILED TOP-VIEW DIAGRAM.....	51
<b>8.</b>	<b>SCHEMATICS</b> .....	<b>52</b>
<b>9.</b>	<b>PARTS LIST</b> .....	<b>55</b>
<b>10.</b>	<b>NHRC LLC LIMITED WARRANTY</b> .....	<b>57</b>

## 1. Introduction

The NHRC-3+ Repeater Controller represents the current state-of-the-art in repeater controller designs. It utilizes the latest available technology to provide maximum functionality with the lowest number of parts. This results in very reliable operation.

The key features of the NHRC-3+ are:

- Recording of two real speech ID messages, one real speech time-out message, and one real speech tail message.
- Local language support using a custom recording capability.
- Simplex repeater mode.
- Unique courtesy tones to indicate status of digital input ports.
- 4 digital outputs.
- Transmitter fan control output automatically runs fan while transmitting and for a programmable delay after.
- DTMF, "Carrier," "Carrier and CTCSS," and "Carrier or CTCSS" access modes.
- Granular security features that allow tailored control operator access.

# NHRC-3+ User Guide

---

## 1.1 Sending commands

All of the controller's commands are sent by DTMF (Touch-Tone®) sequences that are received on the main repeater. DTMF tones received will be evaluated, and if correct, executed, when either the DTMF inter-digit timer expires (2.0 seconds) or the CAS (receiver unsquelched) signal drops; whichever comes first. This allows the controller to be commanded even when a weak on-channel signal is holding the receiver's squelch open.

**To send a command** over the main repeater:

1. Key your transmitter.
2. Enter the DTMF command digits.
3. Unkey the transmitter.

This will cause the command to be evaluated immediately.

If you pause for more than 2.0 seconds while sending a command, the command you entered prior to the pause will be evaluated, the command buffer will be emptied, and you can immediately enter another command.

When a command is successfully evaluated, the controller will send a response. Each command's possible responses are detailed with the command description.

In general, if you do not receive a command response, then the controller did not accept your command.

---

## 1.2 ID Messages

The controller supports two voice ID messages and one CW ID.

The voice messages are comprised of:

- an "initial" ID message, that plays when the controller has been idle for a period longer than the ID timer, and
- a "normal" ID message, that plays during repeater use.

Each of the ID messages can be individually enabled or disabled. The CW ID will play when a voice ID message is required but disabled. The CW ID will also play if the ID timer expires during a user's transmission. The controller tries to be "polite" when identifying; if it is almost time to ID when a user unkeys, the ID is sent immediately.



# NHRC-3+ User Guide

---

## **1.3 “Unlocked Mode”**

All of the controller’s important programming information is protected by a special password, the “unlock code.”

Programming the unlock code requires physical access to the controller to place a jumper on the circuit board.

The unlock code cannot be programmed without physical access to the controller.

When the unlock code is successfully entered into the controller, the controller will transmit “OK” in CW, and a special courtesy tone will be used to indicate the controller is unlocked.

The controller can be locked by:

- Sending the “#” command, or
- The controller will lock itself after two minutes of inactivity.

When the controller leaves the unlocked mode:

- The courtesy tone will revert to the normal tone for the controller’s current state.

## **1.4 Simplex Repeater Controller Mode**

The NHRC-3+ supports a “Simplex Repeater Controller” mode for simplex repeaters. In this mode, the controller will record up to 90 seconds of audio from the receiver, and then repeat that audio to the transmitter. The controller normally waits in “listen” mode, and when the receiver becomes active, it records up to 90 seconds of the received audio into the ISD voice storage chip. When the receiver becomes inactive, the controller will then key the transmitter and play the recorded message. (See section 4.2 for information on setting Simplex Repeater Mode.)

The NHRC-3+ supports a “voice ID” mode when operating as a simplex repeater. When this mode is selected, the first ¼ of the ISD voice storage chip is used to store a recorded voice ID message. This reduces the storage available for simplex repeater transmissions to approximately 67 seconds. (See section 4.2 for information on setting Simplex Repeater Mode.) If the voice ID mode is not selected, the NHRC-3+ can ID the simplex repeater in CW.

For Amateur Radio operation, you should read and understand the FCC Part 97 regulations prior to operating a simplex repeater.

## 2. Electrical Connections

This section of the User Guide describes the electrical interfaces used to connect the controller to:

- Power
- Repeater
- Communications Specialists TS-64 CTCSS Encoder/Decoder
- NHRC-DAD digital audio delay board.

It is intended for the repeater operator to use in the planning and installation of the NHRC-3+ Repeater Controller into a repeater system.

---

### ***2.1 Input and Output Signal Levels.***

Control signals into the controller are active-high signals. The repeater activity inputs (CAS and CTCSS Decode) are buffered to allow the connection of popular radios to the controller. Signal levels should be 0.0 to 0.5 volts for off, and 2.0 to 16.0 volts for on. Expansion port signal levels are TTL compatible.

The controller's PTT and FAN CONTROL outputs are "open-drain" connections to power MOSFETs. These outputs are active-low, and when activated, will pull the control signals to within a few ohms of ground. These outputs can sink 100 mA or so. NHRC recommends that diodes be used to protect the MOSFETs from back-EMF if these signals are used to drive relays.

Audio signals into the controller should be in the range of 0.2 to 2.0 volts peak-to-peak. The controller's transmit audio outputs are adjustable from about 0.1 volt to about 5 volts peak-to-peak.

# NHRC-3+ User Guide

---

## 2.2 J2: Controller/Repeater Interface

The controller uses a 10 pin .100 header for all signals. It requires receiver audio and a signal present indication (CAS) from the receiver, supplies transmit audio and PTT to the transmitter, and requires 13.8 volts DC for power. Be very careful when wiring DC power to the controller, reverse polarity will destroy the ICs. The connector pinouts are shown in the table below.

**J2 REPEATER Electrical Connections**

Pin	Use
1	+13.8 Volts
2	+13.8 Volts
3	CAS+
4	Fan Control/Digital Output
5	PTT (active low)
6	Ground
7	TX Audio (to transmitter)
8	Ground/TX Audio Return
9	RX Audio (from receiver)
10	Ground/RX Audio Return

## 2.3 J1: NHRC-DAD Interface

J1 is provided for the connection of an optional NHRC-DAD digital audio delay. The NHRC-DAD, in conjunction with the NHRC-3+, can completely mute DTMF and eliminate squelch crashes from the repeater audio.

**J1 DELAY Electrical Connections**

Pin	Use
1	+13.8 Volts to delay board
2	Audio to delay board
3	Audio from delay board
4	Ground/Audio Return

⇒ **Note:** If a NHRC-DAD is not connected, then a jumper should be installed between pin 2 and pin 3. If there is not a NHRC-DAD or a jumper, then the controller will not pass audio.

# NHRC-3+ User Guide

---

## 2.4 JTS64: TS-64 Interface

Connector JTS64-pin header that allows the easy installation of an optional Communications Specialists TS-64 for CTCSS decode and encode. Consult Table JTS64 for hookup information.

**JTS64 TS-64 Connector**

Pin	Use	to TS-64 Signal
1	+13.8 Volts	+13.8V In
2	Receiver Audio	Decoder In
3	Receiver Audio	N/C
4	Filtered Audio	High Pass Filter Out
5	CTCSS Detect	Decoder Out
6	Ground / Audio Return	PTT Input, Hangup

If the TS-64 is installed, then jumper JP1 should be removed to utilize the TS-64's high-pass filter, which will remove the CTCSS tone from the repeater audio. If you do not want to use the high-pass filter, do not connect the TS-64 High-Pass Filter Out wire to pin 4 and leave JP1 installed.

# NHRC-3+ User Guide

## 2.5 J3: Expansion Connector

**Warning:** Failure to read and follow the instructions below could result in severe damage to your controller. Damage to the controller caused by improper use of the expansion port is not covered under warranty by NHRC.

The NHRC-3+ has an expansion connector to allow users to interface custom hardware to the controller. The expansion connector has unbuffered microcontroller port signals which must be conditioned to safely interface the controller to external devices. Signals at improper levels can cause the destruction of the port pins, microcontroller, or destroy the repeater controller itself. Your use of this interface is completely at your own risk, and is not supported by NHRC.

### J3 Expansion Connector

Pin	Signal	Description
1	+5 Volts	Regulated +5 Volts
2	CTSEL1	Courtesy Tone Select Input 1
3	CTSEL2	Courtesy Tone Select Input 2
4	OUT1	Digital Control Output 1
5	OUT2	Digital Control Output 2
6	OUT3	Digital Control Output 3
7	OUT4	Digital Control Output 4
8	Ground	Ground

### 2.5.1 Courtesy Tone Selection

Pins 2 and 3 of the expansion connector can be used to select alternate courtesy tones to indicate alarm status, voted receiver status, etc. These pins are configured as inputs to the microcontroller, and have an internal weak pullup resistor to set the state of the pins when they are not connected. NHRC recommends that an external pullup resistor of 10K ohms be used to pull these inputs to +5 volts. When the inputs are pulled to ground, different courtesy tones are selected as shown below.

### Courtesy Tone Selection

CTSEL1	CTSEL2	Courtesy Tone Selected
High	High	Courtesy Tone 3
Low	High	Courtesy Tone 2
High	Low	Courtesy Tone 1
Low	Low	Courtesy Tone 0

### 2.5.2 Digital Output Ports

Pin 3 through 7 (OUT1–OUT4) are active high outputs, that are used as digital outputs 1 through 4. These pins can sink or source a maximum current of 20 mA, however NHRC recommends a maximum of 5 mA in or out of these pins. The state of these digital outputs can be stored in a saved setup.

# NHRC-3+ User Guide

---

## 2.5.3 Power and Ground connectors

Pin 1 provides regulated 5 volts for your interface circuitry, i.e. to provide +5 VDC to the pullup resistors used for the courtesy tone selection inputs. This power source should not be used to power external loads under any circumstances.

Pin 8 provides a ground return for your external expansion logic circuits. This ground source should not be used as the return for any external loads controlled by the controller.

## 2.6 Audio Level Adjustment

### Description of Audio Processing:

The NHRC-3+ uses analog switching and audio mixing to route audio from audio sources to the transmitter port and voice recorder.

The controller's audio path is described in detail below.

The main receiver's audio is passed into the controller through potentiometer VR1, and then buffered through audio amplifier U3A for impedance isolation and equalization. This amplifier can be set up to provide flat audio response or 6 dB/octave de-emphasis with a roll-off of approximately 250 Hz, allowing the use of discriminator audio. The buffered audio is then passed to touch-tone decoder U3, and through connector J1 to the *optional* digital audio delay board for squelch tail elimination. If the digital audio delay is not present, J1 pins 2 and 3 must be jumpered to allow audio to continue to pass through the controller. After the digital audio delay connector, the main receiver audio is gated through analog switch Q4. The gated audio is supplied to the transmitter mix bus via potentiometer VR3, and into the digital voice recorder (DVR) chip via potentiometer VR2.

Flat or de-emphasized audio on the repeater port is simply selected by moving the shorting jumper from (N) normal position to (D) de-emphasized position. Note: if the jumper is completely removed, the audio processing circuit will provide approximately a 10X audio gain with flat response.

Courtesy tones are generated directly by the microprocessor U5, filtered, and provided to the transmitter mix bus through potentiometer VR5.

DVR output is provided to the transmitter mix bus through potentiometer VR4.

Phone audio is provided to the transmitter audio mix bus through potentiometer VR2, buffer amplifier U1C, and analog switch U3D.

The transmitter mix bus is provided to the main transmitter through buffer amplifier U3B, with its level adjusted with potentiometer VR6.

### Description of Controls:

VR1 sets the receiver audio input level into the controller, and, more critically, into the DTMF decoder.

VR2 sets the receiver audio level into the ISD voice recorder IC.

VR3 sets the receiver audio level into the transmitter mix bus.

VR4 sets the recorded speech level into the transmitter mix bus.

VR5 sets the beep level into the transmitter mix bus.

VR6 sets the transmit audio master level.

# NHRC-3+ User Guide

---

## Audio Level Setup:

Recommended equipment:

- Signal generator or another method of generating a RF signal for the main receiver, modulated with a 1 KHz tone at 3 KHz deviation.
- Deviation meter.
- A Service Monitor is recommended for overall ease of alignment.

## Procedure:

The reference level will be a 1 KHz tone at 3 KHz deviation.

1. Prepare the controller for audio alignment by setting all potentiometers to the midrange position, and properly configuring the input equalization (normal or de-emphasized) by setting jumper JP3 to the appropriate pins.
2. Transmit the reference tone through the repeater, and adjust VR1 for reasonable transmitted deviation, about 3 KHz. The final adjustment of VR1 will occur later. Turn off the reference signal.
3. Transmit some DTMF tones into the repeater, and adjust VR1 for reliable DTMF decoding, as indicated by LED D2.
4. Use VR3 to set the received audio repeat level.
5. Use VR5 to set the courtesy tone to a reasonable level.
6. Unlock the controller and force it to transmit the recorded voice ID with the \*800 command. Set the DVR playback level with VR4. Lock the controller.
7. Set the DVR input level. This is best set by setting the controller into simplex mode, recording a test message and allowing it to play back. Adjust the input level so that the test message is played back at the same level as it originally passed through the repeater. Overdriving the DVR will result in compression of recorded audio, complete with “noise pumping” effects, so it is important that the level is not set too high.
8. *Hint:* With the controller in duplex mode (not simplex), set up your signal generator with the test tone. Note the deviation of the *repeater's* transmitted signal. Shut off the generator. Now set the controller into simplex mode and send the test tone for 15 or 20 seconds, then turn off the test tone. The DVR will now play back the recorded test tone. Note the deviation. Repeat this test and adjust the DVR input until the record and playback deviation is the same. ***Be careful*** to remember to subtract out your CTCSS deviation to get a true DVR deviation measurement.
9. If necessary, the output level of the controller can be adjusted with VR6.



# NHRC-3+ User Guide

---

## 2.7 The LED Indicators

The NHRC-3+ has four LED indicators. These LEDs indicate the state of various inputs and outputs of the controller. The LEDs are particularly useful during setup. The LEDs display the following information:

**NHRC-3+ LED Indicator Functions**

LABEL	COLOR	USE
<b>PTT</b>	<b>Red</b>	<b>Transmit Indicator</b>
<b>DTMF</b>	<b>Yellow</b>	<b>DTMF Detect Indicator</b>
<b>COR</b>	<b>Green</b>	<b>Unsquelled Indicator</b>
<b>PL</b>	<b>Green</b>	<b>CTCSS Detect Indicator</b>

All LEDs can be disabled to reduce power consumption by removing jumper JP2.

## 3. Programming the Controller

This section of the User Guide describes how the repeater operator programs the repeater.

It is intended for repeater operators and users who have an interest in how the controller is customized for specific configurations.

⇒ **Note:** \*n commands are only available when the controller has been unlocked by sending the unlock command.

---

### 3.1 Quick Setup

This section of the User Guide is intended to get a first-time user “up and running” quickly using a minimum of the customizable features.

NHRC-3+ controllers are shipped from the factory enabled, with test audio tracks recorded for all four messages, and all command prefixes programmed to the default values. Once your controller is installed and functioning, you should follow the procedure described in this section to begin to customize its operation to suit your needs.

Note that the initialization process described below will completely reset the controller to the factory defaults. All the test voice messages will be deleted, and the repeater will be set as *disabled*. This allows users with a simplex repeater to program their controller. Once initialized, the controller will appear to be dead except when valid commands are entered, until the repeater is enabled.

**You are not required to use this procedure.** It is completely possible to program the NHRC-3+ as shipped from the factory without initialization, unless you plan to use it on a simplex repeater. In the case of simplex repeater use, initialization will help since it will cause the controller to power up with the repeater disabled.

#### Procedure:

- **Make all the necessary electrical connections.** See Section 2.
- **Install the initialize jumper** (JP4, located adjacent to the 28-pin skinny DIP CPU chip.)
- **Apply power to the NHRC-3+.** After a short pause, the controller will transmit “NHRC 3 PLUS” in CW. At this time, NHRC recommends that you immediately program the unlock code.
- **Leave the initialize jumper installed** for this operation.
- **Send the default unlock code (04) to the controller.** The controller should respond with a CW “OK”
- **Use the \*2 command to program command prefix 04: the unlock prefix.** To program the unlock code to 314159, send the following command: \*204314159.
- **Send the “#” command to lock the controller.** The controller should respond with a CW “OK” message.
- **Remove the initialize jumper** (JP4, located adjacent to the 28-pin skinny DIP CPU chip.)

## NHRC-3+ User Guide

---

You should record the voice ID messages (#0, 1), the time-out message (#2), the tail message (#3) and program the CW ID at this time. (See Sections 3.10.1 and 3.11.2 for information on programming the CW ID and recording voice messages.)

This is a good time to program all the command prefixes. (See Section 3.5 for information on programming command prefixes.)

⇒ **Note:** After initialization, the controller will respond to commands, but will not function as a repeater until repeater operation is enabled. This allows the controller to be configured in simplex repeaters. See section 4.1 for information on enabling the repeater.

⇒ **Note:** NHRC strongly recommends that you do not leave the initial default command prefixes in the controller.

## 3.2 Initializing the Controller

Initializing the controller will re-program the controller's non-volatile EEPROM memory with the factory defaults. All customized settings are lost, including command prefixes, timer presets, the CW ID, and the voice messages are reset.

⇒ **Note:** The controller should never require initialization except for new installations.

⇒ **Note:** After initialization, the controller will respond to commands, but will not function as a repeater until repeater operation is enabled. This allows the controller to be configured in simplex repeaters. See section 4.1 for information on enabling the repeater.

### Procedure:

- **Install the initialize jumper** (JP4, located adjacent to the 28-pin skinny DIP CPU chip.)
- **Apply power to the controller.** After a short delay of about 10 seconds, the controller will sent the CW message "NHRC 3 PLUS".
- **Remove the initialize jumper** (otherwise the controller will initialize again the next time it is powered up).

⇒ **Note:** DO NOT LEAVE THE INITIALIZE JUMPER INSTALLED.

See the Appendix of factory defaults for the controller.

## 3.3 \*0: Unlocked Mode Control Operator Access

---

### 3.3.1 Set Control Operator Switches

The \*0 command allows access to all control operator switch groups, including groups 6 and 7 which are not accessible using the control operator prefix. Groups 6 and 7 help to implement controller security by controlling write access to controller data and control operator access to the other eight groups.

The format of this command is

\*0<g><i><s> where:

- <g> specifies the group number. Valid range is 0 to 9.
- <i> specifies the switch number. Valid range is 0 to 7.
- <s> is optional. If present, it is the new state of the switch. Valid values are 0 and 1.

Upon receipt of a valid \*0 command without the state, the controller will transmit the current state of the selected control operator switch.

**Example:** Sending the command \*000 will inquire of the state of control operator group 0 item 0, and the controller will read back the current state: either “ON” or “OFF” in CW.

See Section 4 for more information about control operator switches.

## 3.4 \*1: Save Setup

The NHRC-3+ Repeater Controller has two “saved configuration setups” that allow the repeater operator to save two presets of all 64 of the control operator switches.

The default setup is #0, which is loaded when the controller is powered up.

---

### 3.4.1 Save configuration setup

\*1<n> where:

<n> specifies the setup number to save. Valid range is 0 or 1.

After a valid command is received, the controller will respond with “OK” in CW.

A saved setup can be loaded by using the load saved setup command:

(See Section 5.3 for information about the Load Saved Setup command.)

<p><b>Example:</b> To save the current controller state (all 10 control operator switch groups) as state #1, send the following command with the controller unlocked: “*11”. The controller will transmit "OK" in CW if the command is accepted.</p>
--

## **3.5 \*2: Program Command Prefixes**

Every command accepted by the NHRC-3+ controller when it is locked consists of a command prefix and optional command arguments.

Each prefix can be programmed to restrict access to certain functions to only those users who know the prefix. This gives the repeater operator the ability to only allow specific users to access certain features.

### **Command Prefix Rules:**

- A command prefix is one to seven digits long.
- A command prefix cannot be left blank.
- No two command prefixes should be programmed the same, or be programmed the same as the beginning of a different prefix. For example, do not program the control operator prefix to 1234 and the digital output control prefix to 12345, because the controller would not understand whether 123456 was intended to set control operator switches or change the state of the digital outputs.

Section 6.1.1 describes the Factory Default Command Prefixes.

# NHRC-3+ User Guide

---

## 3.5.1 Set command prefix

\*2<pp><prefix> where:

<pp> specifies the prefix number to set. Valid values are in the range 00 to 15. Two digits must be used. See the Command “Prefixes by Number Table” to determine the prefix number you want to set.

<prefix> specifies the new prefix to assign. Must be 1 to 7 digits in length. The valid digits are 0-9, A-D, \* and #.

After a valid command is received, the controller will respond “OK.”

### Command Prefixes by Number

<u>Prefix Number</u>	<u>Description</u>
00	<b>Control Operator</b>
01	<b>DTMF Access</b>
02	<b>Digital Output Control</b>
03	<b>Load Saved Setup</b>
04	<b>Unlock Controller</b>

⇒ **Note:** For security reasons, command prefixes will never be sent over the air by the controller.

**Example:** To set the DTMF access prefix to 4321, send the following command with the controller unlocked: “\*2014321”. The controller will respond with a CW “OK” if the command is accepted.

⇒ **Note:** For security reasons, *command prefix 04 (the unlock code) cannot be changed unless the initialize jumper (JP4) is installed*. This means that the unlock code cannot be changed without physical access to the controller. To change the code, install the jumper, enter the command, and remove the jumper. Do not leave the initialize jumper installed, and do not power up the controller with the initialize jumper installed, unless you want to reset the controller to factory defaults.

⇒ **Caution:** Do not set any prefix to use the same initial digits as any other prefix, because the controller will not be able to tell the difference between them. For example, if the DTMF access code is set to “123”, and the load saved setup code is set to “1234”, then when a user sends “1234123456” the controller will try to load saved setup 56 rather than enabling the controller in DTMF access mode.



# NHRC-3+ User Guide

---

## 3.6 \*3: Set timers

The NHRC-3+ has nine “timers,” one of which is not really a timer, but is an event counter.

Each timer has its own resolution which is the amount of time each timer count represents.

For example, the hang timer’s resolution is .1 second. To program a hang time of 5.0 seconds, the hang timer would actually be programmed to 50 because there are 50 .1 second intervals in 5.0 seconds.

The tail message counter is used to play the tail messages every n<sup>th</sup> time the tail timer expires.

### 3.6.1 Description of Timers

Timer 00 (hang timer long) and 01 (hang timer short) are “hang” timers. One of these timers can be selected. The hang timer specifies the amount of time the transmitter stays on after the receiver input signal goes away. This is sometimes called the “tail” timer. You can select either the long hang timer or the short hang timer. The resolution of the hang timers is .1 seconds.

Timers 02 is the ID timer. This timer controls how long the period is before a CW ID message is sent. This timer is set in tens of seconds. For example, to set a 9 minute ID timer interval: 9 minutes is 540 seconds, so the timer would be set for 54.

Timer 03 is the DTMF access mode timer. In DTMF access mode, the repeater is activated by sending a DTMF command. The repeater can be de-activated with another DTMF command, or if a period of inactivity occurs. The DTMF access mode timer sets the amount of inactivity before the repeater automatically deactivates. This timer has a 10 second resolution.

Timers 04 (timeout timer long) and 05 (timeout timer short) control the timeout period. Timeout is the maximum amount of time the receiver can be active before the repeater assumes a stuck mike and stops repeating. These timers are set with a 1 second resolution.

Timer 06 (fan timer) controls how long the fan control output will remain active after the controller’s PTT signal is released. This timer uses 10-second resolution.

Timer 07 is the “tail message counter.” This timer is actually a counter. It sets the number of times the repeater “tail” (hang time) must end before the tail message plays.

Timer 08 (CW pitch) and Timer 09 (CW speed) allow the repeater owner to tailor the tone of the transmitted CW characters. They are technically not timers, but parameter settings. The CW pitch can be set to any of the 32 tones shown in section 6.1.3, and the CW speed set from 5 to 30 WPM.

# NHRC-3+ User Guide

---

## 3.6.2 Program a timer

The NHRC-3+ timers are programmed as follows:

**\*3<nn><time>** where:

- <nn>** specifies the timer to set. Valid range is 00 to 12. Both digits must be present. Consult the NHRC-3+ Timers by Number Table for the timer number.
- <time>** The value to program the timer to. The valid range for <time> is 0 to 255.

After a valid set timer command is received, the controller will respond with the word "OK" in CW.

### NHRC-3+ Timers, by Number

<u>Timer No.</u>	<u>Description</u>	<u>Timer Resolution</u>
00	<b>Hang timer long</b>	<b>0.1</b>
01	<b>Hang timer short</b>	<b>0.1</b>
02	<b>ID timer</b>	<b>10</b>
03	<b>DTMF access timer</b>	<b>10</b>
04	<b>Time-out timer long</b>	<b>1</b>
05	<b>Time-out timer short</b>	<b>1</b>
06	<b>Fan timer</b>	<b>10</b>
07	<b>Tail Message Counter</b>	<b>1</b>
08	<b>CW Pitch</b>	<b>N/A</b>
09	<b>CW Speed</b>	<b>N/A</b>

#### ***Examples:***

To program the ID timer to six minutes (360 seconds), send the following command with the controller unlocked: "\*30236". If the command is accepted, the controller will respond with "OK" in CW.

To set the long hang timer for 20 seconds, send the following command with the controller unlocked: "\*300200". If the command is accepted, the controller will respond with "OK" in CW.

### **3.7 \*4: (*Reserved for NHRC*)**

This command is reserved by NHRC for future expansion.

### **3.8 \*5: (*Reserved for NHRC*)**

This command is reserved by NHRC for future expansion.

### **3.9 \*6: (*Reserved for NHRC*)**

This command is reserved by NHRC for future expansion.

# NHRC-3+ User Guide

---

## 3.10 \*7: Program CW and Beep Messages

The \*7 command is used to program or play the CW ID and courtesy tones.

---

### 3.10.1 Program a CW ID

The CW ID can be programmed or played with the \*70 command, as follows:

**\*70<dd..dd..dd..>** where:

**<dd...dd...dd...>** is the CW ID message. If left blank, the current CW ID message will play. When present, the part of the command represented by **<dd..dd..dd..>** consists of 1 to 12 digit pairs. Each pair of digits represents one CW character.

(See Section 6.1.4, the CW Character Table, to look up the code for each CW character.)

<p><b>Example:</b> To program “DE N1KDO/R” as the CW ID, the following command would be entered: *70 31 32 11 62 01 52 63 12 72.</p>
--

# NHRC-3+ User Guide

## 3.10.2 Program or play courtesy tones

The NHRC-3+ supports eight different courtesy tones. Courtesy tones are composed of up to four segments of tones. Each segment has a tone frequency and duration.

The courtesy tone is selected based on the logic levels present at expansion connectors CTSEL1 and CTSEL2. If no signals are connected to these pins, then courtesy tone 3 is used. (Consult section 0 for information on the electrical interfacing to the expansion connectors.)

The courtesy tones are played and programmed with command \*71 as follows:

**\*71<n><ddtt ddtt ddtt ddtt>** where:

**<n>** is the courtesy tone number to play or program. The valid range of values is 0 to 7.

**<ddtt ddtt ddtt ddtt>** is up to four sets of duration and tone.

Duration is in 10 ms increments; valid range is 01-99. Both digits must be specified. Tone is the number of the tone from Section 6.1.3, the Courtesy Tone Components Table.

**Example:** The default courtesy tone #0, (four 50MS bursts of notes E5, G5, B5, D6) would be programmed like: \*7100517052005240527.

### Courtesy Tone Uses

<u>Tone</u>	<u>Use</u>
0	<b>Normal courtesy tone, CTSEL1=0, CTSEL2=0</b>
1	<b>Normal courtesy tone, CTSEL1=1, CTSEL2=0</b>
2	<b>Normal courtesy tone, CTSEL1=0, CTSEL2=1</b>
3	<b>Normal courtesy tone, CTSEL1=1, CTSEL2=1</b>
4	<b>Reserved</b>
5	<b>Reserved</b>
6	<b>Reserved</b>
7	<b>Controller unlocked courtesy tone</b>

# NHRC-3+ User Guide

---

## 3.11 \*8: Play/Record Voice Tracks

The NHRC-3+ supports stored voice messages. The repeater operator will want to record all of these messages. The \*8 command allows the repeater operator to record their preferred voice messages.

The controller's speech IDs, tail messages, time-out message, etc. should all be recorded by the repeater operator.

---

### 3.11.1 Play a message

Command \*80 is used to play messages:

**\*80<n>** where:

**<n>** is the message to be played. Valid range for <n> is 0 – 3.

**Example:** To play back the initial ID message (message #0), send the following command with the controller unlocked: "\*800". The controller will play back the initial ID message.

### NHRC-3+ Stored Speech Messages

Message Number	Usage
0	Initial ID message
1	Normal ID message
2	Time-out message
3	Tail message/courtesy tone

## 3.11.2 Record a message

Command \*81 is used to record messages.

**\*81<n>** where:

**<n>** is the message to be recorded. Valid range for <n> is 0 – 3.

To record a message, enter \*81, followed by the message number you want to record. The controller will prompt you sending “OK” in CW. After the prompt, key your radio and speak clearly to record the message. The recording is terminated when either you stop transmitting or the message slot is full (that is, the slot’s message time is all used). The controller will transmit “OK” again after the message is recorded.

**Example:** To record the tail message (message # 3), send the following command with the controller unlocked: “\*813”. The controller will respond with a CW “OK”. Key your radio, and transmit your voice message you want to record. Recording ends either when you unkey, or the maximum message length for the message is reached, whichever comes first. The controller will acknowledge recording your message with a CW “OK.”

## 3.12 \*9: (Reserved for NHRC)

This command is reserved by NHRC for future expansion.

## 3.13 \*\*: Reset Controller

Command \*\* is used to reset the controller to the power-up state for any reason.

The controller will send “NHRC 3 PLUS” in CW, then play the initial ID.

## 4. Control Operator Commands

The NHRC-3+ supports 64 different control operator settings arranged into eight different groups of eight “software switches.” Each software switch represents an item in the controller that can be set to either on or off. Every switch is addressed by naming the group, then the item number. There are eight groups of eight items each.

---

The format for all control operator commands is:

**<ctl-op-prefix><group><item><state>**

- <ctl-op-prefix>** The control operator prefix assigned by the repeater operator. (See Section 3.5 for information on Programming Command Prefixes.)
- <group>** The group code for the switch to set or inquire. The valid range for <group> is 0 to 7. Groups 8 and 9 can only be accessed with the programming \*0 command. (See Section 3.3 for information about \*0: Unlocked Mode Control Operator Access.)
- <item>** The item number to set or inquire. The valid range for <item> is 0 to 7.
- <state>** is optional. If present, it is the state (1=on, 0=off) to which the control operator switch is to be set.

When <state> is not present, or after a successful control operator command that sets the switch state, the controller will respond by transmitting either the word “ON” or the word “OFF”, depending on the state of the particular switch.

For example, to set group 0 item 0 to enabled, the following command would be sent: *<ctl-op-prefix>001*.

The controller will respond by transmitting the word “ON” in CW.

All 64 of the control operator switches are saved when the controller’s state is saved. Saved state 0 is the power-up state, so if you want to make your changes to the control operator switches be restored after a power failure, it is important to save the controller’s state. See section 3.4 for information on the Save State Command.



# NHRC-3+ User Guide

---

## 4.1 Group 0 Switches: Repeater Control

Group 0 contains switches that control the main repeater and access to the main repeater.

### Group 0 Switches:

<u>Switch</u>	<u>Name</u>	<u>Description</u>
0	Repeater Enable	This is the repeater's master enable/disable control. Set this to 0 to disable the repeater.
1	Repeater CTCSS Required	Allows the repeater to be set into a CTCSS required mode when enabled. When disabled, the repeater is carrier access. Note: If CTCSS Required <b>and</b> "dual squelch" mode are both selected, then the controller will require valid CTCSS for access, <i>unless the hang timer is running</i> . This mode allows the repeater to be activated by a user with the valid CTCSS tone, but then accessed by users without CTCSS, or to be activated with a 1750 Hz. tone for countries that require tone-burst access.
2	Key Up Delay ("Kerchunker Filter")	Allows the "kerchunker filter" to be enabled. The "kerchunker filter" requires a signal for more than 1/2 second before the repeater will begin to repeat, but only when the transmitter is not on.
3	Hang Timer Enabled	Normally enabled, but can be disabled when the repeater runs on battery power, or to discourage "kerchunkers."
4	Hang Timer Select	Allows the control operator to select which hang timer value is used. Allows the long (1) or short (0) timer to be selected.
5	DTMF Access Mode Select	Allows the control operator to place the repeater into DTMF access mode. In DTMF access mode, the repeater, when idle, can only be activated by sending the DTMF access prefix, followed by a 1 to enable the repeater. The repeater will remain active until either disabled with the DTMF access prefix followed by a 0, or the repeater remains idle for longer than the time specified in the DTMF access timer.
6	Courtesy Tone Enabled	Allows the courtesy tone to be enabled or disabled.

# NHRC-3+ User Guide

---

## **Group 0 Switches:**

<b><u>Switch</u></b>	<b><u>Name</u></b>	<b><u>Description</u></b>
7	Control Operator CTCSS required	When this switch is enabled, control operator commands will only be accepted when the command is received with a valid CTCSS tone.

# NHRC-3+ User Guide

---

## 4.2 Group 1 Switches: More Repeater Control

Group 1 contains switches that control the main repeater and access to the main repeater.

### Group 1 Switches:

<u>Switch</u>	<u>Name</u>	<u>Description</u>
0	Repeater Time-out Timer Enable	Allows the time-out timer on the main repeater to be enabled or disabled. Normally the time-out timer will be enabled. However, certain applications may require that the time-out timer be disabled (nets, shuttle rebroadcast, etc.). Set this switch to 1 to enable the repeater time-out timer.
1	Time-out Timer Long Select	Allows the long (1) or short (0) timer to be selected.
2	“Dual Squelch” Enable	Setting this switch to 1 enables dual squelch mode. In “Dual-Squelch” mode, either the CAS or the CTCSS signal will cause the repeater to be accessed. This is sometimes called “OR-Squelch” mode.  Note that when this switch is set (1) and the “Repeater CTCSS Required” switch is set (1), (see Group 0 Switches, section 4.1), then the controller will require valid CTCSS for access, <i>unless the hang timer is running</i> . This mode allows the repeater to be activated by a user with the valid CTCSS tone, but then accessed by users without CTCSS, or to be activated with a 1750 Hz. tone for countries that require tone-burst access
3	DTMF Muting Enable	When enabled (1), the controller will mute the receiver audio to prevent received DTMF command tones from being broadcast over the repeater.
4	Reserved	Reserved for NHRC.
5	Reserved	Reserved for NHRC.
6	Simplex Repeater Mode	When enabled (1), the controller will function as a “simplex repeater”, recording up to 90 seconds of audio from the input, and playing it out the output when the input CAS drops.

# NHRC-3+ User Guide

---

## **Group 1 Switches:**

<b><u>Switch</u></b>	<b><u>Name</u></b>	<b><u>Description</u></b>
7	Simplex Repeater Voice ID Mode	When enabled (1), the controller will reserve message #0 (the initial ID track) from the space used for simplex mode, and it will play this track for the ID, rather than the CW ID.

# NHRC-3+ User Guide

---

## 4.3 Group 2 Switches: Voice ID and Misc. Control

Group 2 controls the voice ID and tail messages.

### Group 2 Switches:

<u>Switch</u>	<u>Name</u>	<u>Description</u>
0	Enable Voice Initial ID	When enabled (1), the initial voice ID message is present. If disabled (0), the CWID will play instead of the voice initial ID.
1	Enable Voice Normal ID	When enabled (1), the controller will play the normal ID message voice track (#1) for the “normal” ID. When disabled (0), the controller will play the CW ID for the normal ID.
2	Allow ID Stomp by Keyup	When enabled (1), will allow the controller to cancel a voice ID and play the CW ID if a user begins to transmit while the voice ID is playing.
3	Enable Voice Time-out Message	When set (1), enables the voice time-out message, instead of the CW time-out message “TO.”
4	Digital Output Fan Control	When enabled (1), configures the digital output on the main repeater connector to be a fan control output. A fan connected to this output will run while the transmitter is keyed, and a programmable amount of time after the transmitter is unkeyed. When disabled, this input is controlled by the state of the Group 2 Item 5 (the next) switch.
5	Digital Output Control	When disabled (0), this switch allows the control operator to set the state of the digital output on the main repeater connector.
6	Digital Audio Delay Present	When enabled (1), changes the timing of the CAS logic in the controller to support the use of a NHRC-DAD on the repeater port.
7	Reserved	Reserved for NHRC.

# NHRC-3+ User Guide

---

## 4.4 Group 3 Switches: European ID Mode Control

Group 3 contains switches that are used for European-style ID control.

### Group 3 Switches:

<u>Switch</u>	<u>Name</u>	<u>Description</u>
0	European ID Mode	<p>When enabled (1), the repeater will ID in a mode that is compatible with European rules.</p> <ol style="list-style-type: none"><li>1. When the repeater is idle, activating the repeater will cause the recorded Initial ID to play, and the ID timer reset to the programmed value. The CW ID can be played instead of the Initial ID by setting group 2 switch 0 to 0.</li><li>2. When the repeater becomes idle, either the recorded Normal ID or the CW ID message will be played, and the ID timer reset to the programmed value. The recorded voice Normal ID can be selected instead of the CW ID by setting group 3 switch 1 to 1.</li><li>3. When the ID timer times out (counts down to zero), the recorded Normal ID message will be played, and the ID timer reset to the programmed value. The CW ID can be selected instead of the Normal ID by setting group 2 switch 1 to 0.</li><li>4. The ID will continue to play every time the ID timer times out.</li><li>5. The ID timer is set to 10 seconds at power up.</li></ol>
1	European ID Mode End ID Selector	<p>This switch selects which ID plays when the hang timer times out, and the repeater becomes idle. Set this switch to 0 to play the CW ID, or set this switch to 1 to play the recorded voice Normal ID.</p>
2	Reserved	Reserved for NHRC.
3	Reserved	Reserved for NHRC.
4	Reserved	Reserved for NHRC.
5	Reserved	Reserved for NHRC.

# NHRC-3+ User Guide

---

## **Group 3 Switches:**

<b><u>Switch</u></b>	<b><u>Name</u></b>	<b><u>Description</u></b>
<b>6</b>	Reserved	Reserved for NHRC.
<b>7</b>	Reserved	Reserved for NHRC.

# NHRC-3+ User Guide

---

## 4.5 Group 4 Switches: Expansion Outputs Mode Control

Group 4 contains switches which configure the expansion outputs.

### Group 4 Switches:

<u>Switch</u>	<u>Name</u>	<u>Description</u>
0	Reserved.	Reserved for NHRC.
1	Port 1 Pulsed Mode.	When enabled (1), setting Port 1 to on will cause it to remain on for ½ second.
2	Port 2 Pulsed Mode.	When enabled (1), setting Port 2 to on will cause it to remain on for ½ second.
3	Port 3 Pulsed Mode.	When enabled (1), setting Port 3 to on will cause it to remain on for ½ second.
4	Port 4 Pulsed Mode.	When enabled (1), setting Port 4 to on will cause it to remain on for ½ second.
5	Reserved	Reserved for NHRC.
6	Reserved	Reserved for NHRC.
7	Reserved	Reserved for NHRC.



## 4.6 Group 5 Switches: Expansion Outputs Control

Group 5 contains switches which control the four expansion output ports. Note that these ports can also be controlled with the Expansion Output Control prefix.

### Group 5 Switches:

<u>Switch</u>	<u>Action</u>	<u>Description</u>
0	Reserved	Reserved for NHRC.
1	Port 1 Output Control	When set (1), port 1 will be in a logic 1 state. When clear (0), port 1 will be in a logic 0 state.
2	Port 2 Output Control	When set (1), port 2 will be in a logic 1 state. When clear (0), port 2 will be in a logic 0 state.
3	Port 3 Output Control	When set (1), port 3 will be in a logic 1 state. When clear (0), port 3 will be in a logic 0 state.
4	Port 4 Output Control	When set (1), port 4 will be in a logic 1 state. When clear (0), port 4 will be in a logic 0 state.
4	Reserved	Reserved for NHRC.
5	Reserved	Reserved for NHRC.
6	Reserved	Reserved for NHRC.
7	Reserved	Reserved for NHRC.

# NHRC-3+ User Guide

---

## 4.7 Group 6 Switches: Programming Write Protect

Group 6 contains switches which enable or disable modification to controller data. These switches serve as a “write protect” to help prevent accidental reprogramming of repeater features. Each switch, when enabled (1), write protects its associated setup information. This entire group cannot be accessed by the control operator, it can only be accessed when the repeater is unlocked, by using the \*0 command. (See Section 3.3 for information on the unlocked mode control operator access.)

### **Group 6 Switches:**

<b><u>Switch</u></b>	<b><u>Name</u></b>	<b><u>Description</u></b>
0	Write Protect Control Group Setups	When enabled (1), causes the *1 command (Save Setup) to fail, effectively disallowing control groups to be saved.
1	Write Protect Command Prefixes	When enabled (1), causes the *2 Program Command Prefix command to fail, effectively disallowing modification of the command prefixes.
2	Write Protect Timers	When enabled (1), causes the *3 Set Timers command to fail, effectively disallowing modification of the timer values.
3	Reserved	Reserved for NHRC.
4	Reserved	Reserved for NHRC.
5	Reserved	Reserved for NHRC.
6	Write Protect CW Messages and Courtesy Tones	When enabled (1), causes the *70 and *71 commands to fail when new messages are specified, effectively disallowing modification of the CW ID and courtesy tones.
7	Write Protect Voice Messages	When enabled (1), causes the *81 “record voice message” command to fail, effectively disallowing modification of the voice message tracks.

## 4.8 Group 7 Switches: Control Operator Group Access

Group 7 contains switches which enable or disable control operator access to the control operator groups. This entire group cannot be accessed by the control operator. It can only be accessed when the repeater is unlocked, by using the \*0 command. These switches allow the repeater operator to selectively disable control operator functions on a group-by-group basis, allowing more granularity of controller security. (See Section 3.3 for information on the unlocked mode control operator access.)

### Group 7 Switches:

<u>Switch</u>	<u>Name</u>	<u>Description</u>
0	Enable Control Operator Access to Group 0	When enabled (1), allow the control operator to change the settings in Group 0.
1	Enable Control Operator Access to Group 1	When enabled (1), allow the control operator to change the settings in Group 1.
2	Enable Control Operator Access to Group 2	When enabled (1), allow the control operator to change the settings in Group 2.
3	Enable Control Operator Access to Group 3	When enabled (1), allow the control operator to change the settings in Group 3.
4	Enable Control Operator Access to Group 4	When enabled (1), allow the control operator to change the settings in Group 4.
5	Enable Control Operator Access to Group 5	When enabled (1), allow the control operator to change the settings in Group 5.
6	Reserved	Reserved for NHRC.
7	Reserved	Reserved for NHRC.

## 5. User Commands

This section of the manual describes commands that are available to the repeater users. Every command has a command prefix which is set by the repeater operator. The prefixes can be kept secret, so only certain users have access to certain functions. (See Section 3.5 for more information on programming command prefixes.)

Throughout this section of the manual, the command prefix will be shown as <prefix>, which must be replaced with the actual command prefix as programmed by the repeater operator.

### 5.1 DTMF Access

The NHRC-3+ Repeater Controller supports a DTMF access mode which allows the repeater to be left in a secured disabled state, but users who know the DTMF access code can enable the repeater. The repeater reverts to the secured disabled state when either the repeater is idle for longer than the DTMF Access Mode Timer, or a user sends the DTMF access code followed by a zero.

The repeater is put into DTMF Access Mode by setting control operator group 0, item 5 to enabled (1). (See Section 4.1 for information about this control operator switch, and section 3.5 for information on programming the DTMF Access Prefix and section 3.6 for information on setting the DTMF access timer.)

---

When the repeater is in the DTMF access mode, the DTMF access command is used as follows:

<prefix><state> where:

<prefix> is the DTMF access mode prefix.

<state> is 1 to enable the repeater. <state> is 0 to return the repeater to the secure disabled mode.

**Example:** If the repeater is in DTMF Access Mode, and the DTMF Access Prefix is “567”, the repeater can be activated by sending “5671”. At that time the repeater will remain on until either no activity occurs on the repeater for a period longer than the DTMF Access Mode timer or the repeater is manually deactivated by sending “5670”.

# NHRC-3+ User Guide

---

## 5.2 Digital Output Control

The NHRC-3+ expansion digital outputs can be directly set by a user command.

Each output can be turned on, turned off, or have its state reported.

When an output is turned on, the controller will respond with the word “on” sent in CW. When an output is turned off, the controller will respond with the word “off” sent in CW. When an outputs state is checked, the controller will respond with either “on” or “off” sent in CW, depending on the output’s state.

---

To use the Digital Output Control feature, enter the following command:

**<prefix><port #><state>** where:

**<prefix>** is the Digital Output Control prefix as programmed by the repeater operator

**<port>** is the expansion output number, from 1 to 4.

**<state>** is 1 to turn the port on, 0 to turn the port off. The port’s current state will be reported if the state digit is not sent..

**Example:** Assuming the Digital Output Control prefix is 99, if you want to set output 2 off, you can send “9920” to the controller. The controller will respond with “off” sent in CW. To test the state of output 3, you can send “993” to the controller; the controller will respond with either “on” or “off”, depending on the state of output 3.

# NHRC-3+ User Guide

---

## 5.3 Load Saved Setup

The NHRC-3+ supports two saved setups of all 64 control operator switches. (See Section 3.4 for information about saving the controller state.)

This command allows users or control operators to select one of the preset repeater states.

---

The format for the load saved state command is:

**<prefix><state-number>** where:

**<prefix>** is the load saved state prefix as programmed by the repeater operator.

**<state-number>** is the state to load. Valid state numbers are 0 and 1.

***Example:*** Assuming the Load Saved Setup prefix is set to 314159, and you want to select your “net mode”, saved as setup #1, send “3141591”. The controller will respond with “OK” in CW.

## 6. Appendices

### 6.1 Factory Defaults

#### 6.1.1 Default Command Prefixes Table

Index	Description	Default Prefix
00	<b>Control Operator</b>	<b>00</b>
01	<b>DTMF Access</b>	<b>01</b>
02	<b>Digital Output Control</b>	<b>02</b>
03	<b>Load Saved Setup</b>	<b>03</b>
04	<b>Unlock Controller</b>	<b>04</b>

## NHRC-3+ User Guide

---

### 6.1.2 Timer Defaults Table

Timer Number	Description	Multiplier	Timer Value	Effective Value
00	<b>Hang Timer Long</b>	<b>.1</b>	<b>100</b>	<b>10.0</b>
01	<b>Hang Timer Short</b>	<b>.1</b>	<b>50</b>	<b>5.0</b>
02	<b>ID Timer</b>	<b>10</b>	<b>54</b>	<b>540</b>
03	<b>DTMF Access Timer</b>	<b>10</b>	<b>60</b>	<b>600</b>
04	<b>Time-Out Timer Long</b>	<b>1</b>	<b>180</b>	<b>180</b>
05	<b>Time-Out Timer Short</b>	<b>1</b>	<b>30</b>	<b>30</b>
06	<b>Fan Timer</b>	<b>10</b>	<b>12</b>	<b>120</b>
07	<b>Tail Message Counter</b>	<b>1</b>	<b>0</b>	<b>0</b>
08	<b>CW Pitch</b>	<b>N/A</b>	<b>20</b>	<b>C5</b>
09	<b>CW Speed</b>	<b>N/A</b>	<b>20</b>	<b>20 WPM</b>



# NHRC-3+ User Guide

---

## 6.1.3 Courtesy Tone Component Tones Table

Tone Code	Tone
00	<b>No tone</b>
01	<b>F4</b>
02	<b>F#4</b>
03	<b>G4</b>
04	<b>G#4</b>
05	<b>A4</b>
06	<b>A#4</b>
07	<b>B4</b>
08	<b>C5</b>
09	<b>C#5</b>
10	<b>D5</b>
11	<b>D#5</b>
12	<b>E5</b>
13	<b>F5</b>
14	<b>F#5</b>
15	<b>G5</b>
16	<b>G#5</b>
17	<b>A5</b>
18	<b>A#5</b>
19	<b>B5</b>
20	<b>C6</b>
21	<b>C#6</b>
22	<b>D6</b>
23	<b>D#6</b>
24	<b>E6</b>
25	<b>F6</b>
26	<b>F#6</b>
27	<b>G6</b>
28	<b>G#6</b>
29	<b>A6</b>
30	<b>A#6</b>
31	<b>B6</b>

# NHRC-3+ User Guide

---

## 6.1.4 CW (“Morse Code”) Character Table

Letter	Code
0	<b>00</b>
1	<b>01</b>
2	<b>02</b>
3	<b>03</b>
4	<b>04</b>
5	<b>05</b>
6	<b>06</b>
7	<b>07</b>
8	<b>08</b>
9	<b>09</b>
A	<b>21</b>
B	<b>22</b>
C	<b>23</b>
D	<b>31</b>
E	<b>32</b>
F	<b>33</b>
G	<b>41</b>
H	<b>42</b>
I	<b>43</b>
J	<b>51</b>
K	<b>52</b>
L	<b>53</b>
M	<b>61</b>
N	<b>62</b>
O	<b>63</b>
P	<b>71</b>
Q	<b>70</b>
R	<b>72</b>
S	<b>73</b>
T	<b>81</b>
U	<b>82</b>
V	<b>83</b>
W	<b>91</b>
X	<b>92</b>
Y	<b>93</b>
Z	<b>90</b>
Space	<b>11</b>
/	<b>12</b>

## NHRC-3+ User Guide

---

### 6.2 Control Operator Controls

#### 6.2.1 Control Operator Group 0 (Repeater Control) Operations Table

Group #	Item #	Function	Default	Comments
0	0	Repeater Enable	0	Initialization will leave repeater disabled!
0	1	Repeater CTCSS Required	0	
0	2	Key Up Delay (Kerchunk Filter)	0	
0	3	Hang Timer Enabled	1	
0	4	Hang Timer Short/Long Select	0	0=short, 1=long, see related timer values.
0	5	DTMF Access Mode	0	see related DTMF access code and timer information
0	6	Courtesy Tone Enabled	1	
0	7	Control Op CTCSS Required	0	

#### 6.2.2 Control Operator Group 1 (Repeater Control II) Operations Table

Group #	Item #	Function	Default	Comments
1	0	Repeater Time-Out Timer Enable	1	see related timer value
1	1	Time-Out Long / Short	1	0=short, 1=long, see related timer values short time-out
1	2	Enable "Dual Squelch"	0	allows CTCSS or CAS to provide valid CAS
1	3	Enable DTMF Muting	1	Repeater mutes touch tones
1	4	Reserved	0	
1	5	Reserved	0	
1	6	Simplex Repeater Mode	0	Set to 1 for Simplex Repeater Mode
1	7	Simplex Repeater Voice Id	0	

## NHRC-3+ User Guide

---

### 6.2.3 Control Operator Group 2 (Voice and Tail ID Messages) Operations Table

Group #	Item #	Function	Default	Comments
2	0	Enable Voice Initial Id	1	Plays CW ID if disabled. See CWID programming
2	1	Enable Voice Normal Id	1	Plays CW ID if disabled.
2	2	Allow ID Stomp By Key Up	1	ID reverts to CW when keyed over.
2	3	Enable Voice Time-Out Message	1	Plays CW "TO" when disabled
2	4	Digital Output/Fan Control	0	0=digital output, 1=fan control
2	5	Digital Output Control	0	1=on, 0=off
2	6	Delay Present On Repeater Port	0	NHRC-DAD installed on repeater.
2	7	Reserved	0	Reserved for NHRC

### 6.2.4 Control Operator Group 3 (Reserved for NHRC)

Group #	Item #	Function	Default	Comments
3	0	European ID mode	0	Uses European rules to decide when to ID
3	1	European ID end ID Voice Select	0	Set to 1 to play Voice ID 1 on repeater tail drop.
3	2	Reserved	0	Reserved for NHRC
3	3	Reserved	0	Reserved for NHRC
3	4	Reserved	0	Reserved for NHRC
3	5	Reserved	0	Reserved for NHRC
3	6	Reserved	0	Reserved for NHRC
3	7	Reserved	0	Reserved for NHRC

## NHRC-3+ User Guide

---

### 6.2.5 Control Operator Group 4 (Digital Output Mode Control) Operations Table

Group #	Item #	Function	Default	Comments
4	0	Reserved.	0	Reserved for NHRC
4	1	Port 1 Pulsed Mode.	0	
4	2	Port 2 Pulsed Mode.	0	
4	3	Port 3 Pulsed Mode.	0	
4	4	Port 4 Pulsed Mode.	0	
4	5	Reserved	0	Reserved for NHRC
4	6	Reserved	0	Reserved for NHRC
4	7	Reserved	0	Reserved for NHRC

### 6.2.6 Control Operator Group 5 (Digital Output Control) Operations Table

Group #	Item #	Function	Default	Comments
5	0	Reserved.	0	Reserved for NHRC
5	1	Port 1 Output Control.	0	
5	2	Port 2 Output Control.	0	
5	3	Port 3 Output Control.	0	
5	4	Port 4 Output Control.	0	
5	5	Reserved	0	Reserved for NHRC
5	6	Reserved	0	Reserved for NHRC
5	7	Reserved	0	Reserved for NHRC

## NHRC-3+ User Guide

---

### 6.2.7 Control Operator Group 6 (Programming Write Protect) Operations Table

Group #	Item #	Function	Default	Comments
<b>6*</b>	0	<b>Write Protect Control Group Setups</b>	<b>0</b>	
<b>6*</b>	1	<b>Write Protect Prefixes</b>	<b>0</b>	
<b>6*</b>	2	<b>Write Protect Timers</b>	<b>0</b>	
<b>6*</b>	3	<b>Reserved</b>	<b>0</b>	<b>Reserved for NHRC</b>
<b>6*</b>	4	<b>Reserved</b>	<b>0</b>	<b>Reserved for NHRC</b>
<b>6*</b>	5	<b>Reserved</b>	<b>0</b>	<b>Reserved for NHRC</b>
<b>6*</b>	6	<b>Write Protect CW Messages &amp; Courtesy Tones</b>	<b>0</b>	
<b>6*</b>	7	<b>Write Protects Pre-Recorded Vocabulary Tracks</b>	<b>1</b>	<b>Protects tracks 0-95 against accidental modification</b>

### 6.2.8 Control Operator Group 7 (Control Operator Group Access) Operations Table

Group #	Item #	Function	Default	Comments
<b>7*</b>	0	<b>Enable Access To Group 0</b>	<b>1</b>	
<b>7*</b>	1	<b>Enable Access To Group 1</b>	<b>1</b>	
<b>7*</b>	2	<b>Enable Access To Group 2</b>	<b>1</b>	
<b>7*</b>	3	<b>Enable Access To Group 3</b>	<b>1</b>	
<b>7*</b>	4	<b>Enable Access To Group 4</b>	<b>1</b>	
<b>7*</b>	5	<b>Enable Access To Group 5</b>	<b>1</b>	
<b>7*</b>	6	<b>Reserved</b>	<b>0</b>	<b>Reserved for NHRC</b>
<b>7*</b>	7	<b>Reserved</b>	<b>0</b>	<b>Reserved for NHRC</b>

\* controller must be unlocked to access groups 6 and 7

# NHRC-3+ User Guide

---

## 6.3 Terminology and Abbreviations

<b><u>Term</u></b>	<b><u>Description</u></b>
<b>CAS</b>	Carrier Activated Squelch, where receipt of a signal, with or without CTCSS tones will activate the controller.
<b>CW</b>	Continuous Wave signals, commonly using "Morse Code." The term "CW" refers to the radio emission type, while "Morse Code" refers to the signaling type used. Typically, they are incorrectly used interchangeably.
<b>Digital Audio Delay (DAD)</b>	Digital Audio Delay (DAD) removes squelch crashes and allows DTMF tones to be fully muted.
<b>DTMF</b>	Also known as "Touch Tone®" codes.
<b>Dual Squelch</b>	"Dual Squelch," also known as CAS or CTCSS mode, allows the repeater to be configured with a tight squelch for users without CTCSS, but allows a valid CTCSS to access the repeater even when the signal is not quiet enough to open the carrier squelch.
<b>ID</b>	Identification
<b>PTT</b>	Push-to-Talk
<b>Unlock Code</b>	A special password used to enable programming of the controller.

# NHRC-3+ User Guide

## 7. Circuit Board

### 7.1 Interconnections

Connector	Name	Purpose
<b>J2</b>	“Repeater”	Connects the repeater transmit and receive audio, PTT, CAS, fan control, and power signals to the controller.
<b>J1</b>	“Delay”	Connects power and audio signals for operation of the Digital Audio Delay (NHRC-DAD) board.
<b>JTS64</b>	“JTS64”	Interfaces a Communications Specialists TS-64 to the controller for CTCSS detection.

### 7.2 Jumpers

Jumper	Purpose
<b>JP1</b>	TS-64 High-Pass Filter Jumper. Install jumper if no TS-64 is installed, or audio is not passing through attached TS-64.
<b>JP2</b>	LED Enable jumper. Status LEDs are enabled if jumper is present. Remove for lower-current operation. (Each LED uses about 10 mA when lit.)
<b>JP3</b>	Audio Equalization jumper. Set between center pin and “D” for discriminator audio, center pin and “n” for normal (already deemphasized) audio.
<b>JP4</b>	Initialize/Change Unlock Code jumper. If this jumper is present at controller power-up, then the controller’s non-volatile settings are reset to the factory defaults. This jumper can be installed after the power is up to change the controller’s unlock code. Do not leave this jumper installed after initialization or changing the unlock code, or the controller will initialize on the next power-up.



# NHRC-3+ User Guide

## 7.3 NHRC-3+ Detailed Top-View Diagram

The following diagram is a detailed top view of the Revision "C" printed wiring board for the NHRC-3+ Repeater Controller.

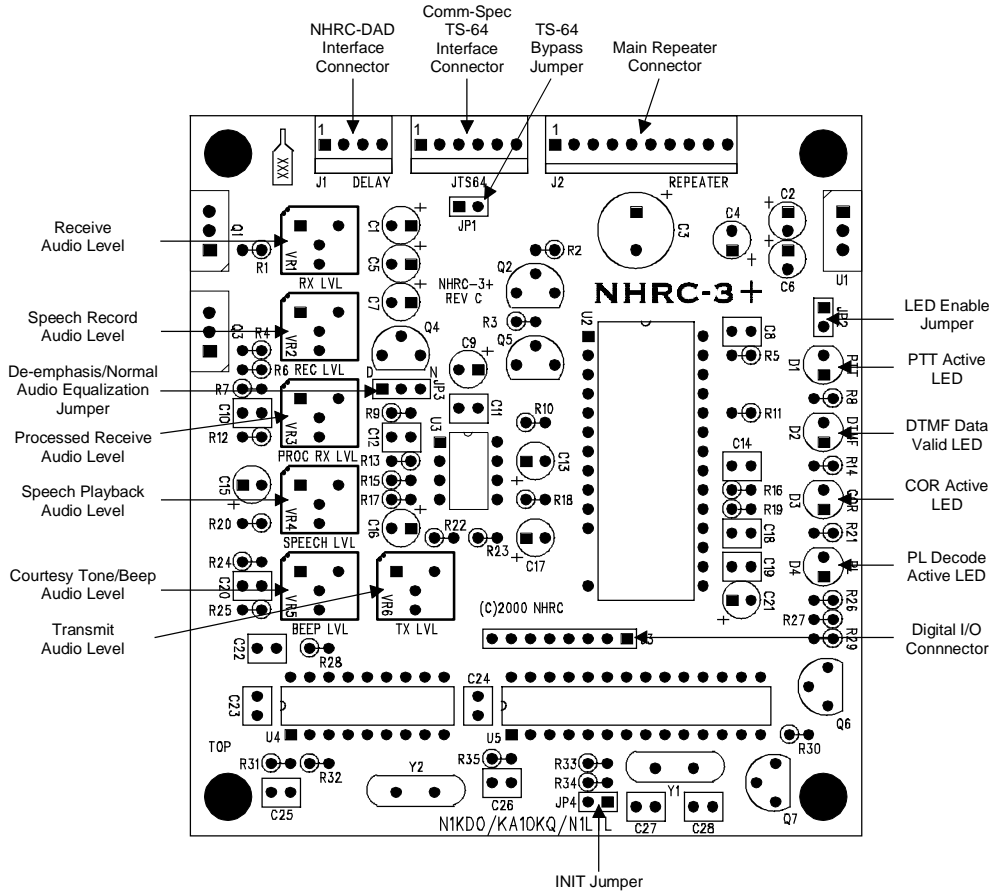

## **8. Schematics**

The following two pages are the schematic diagrams for the NHRC-3+ Repeater Controller.

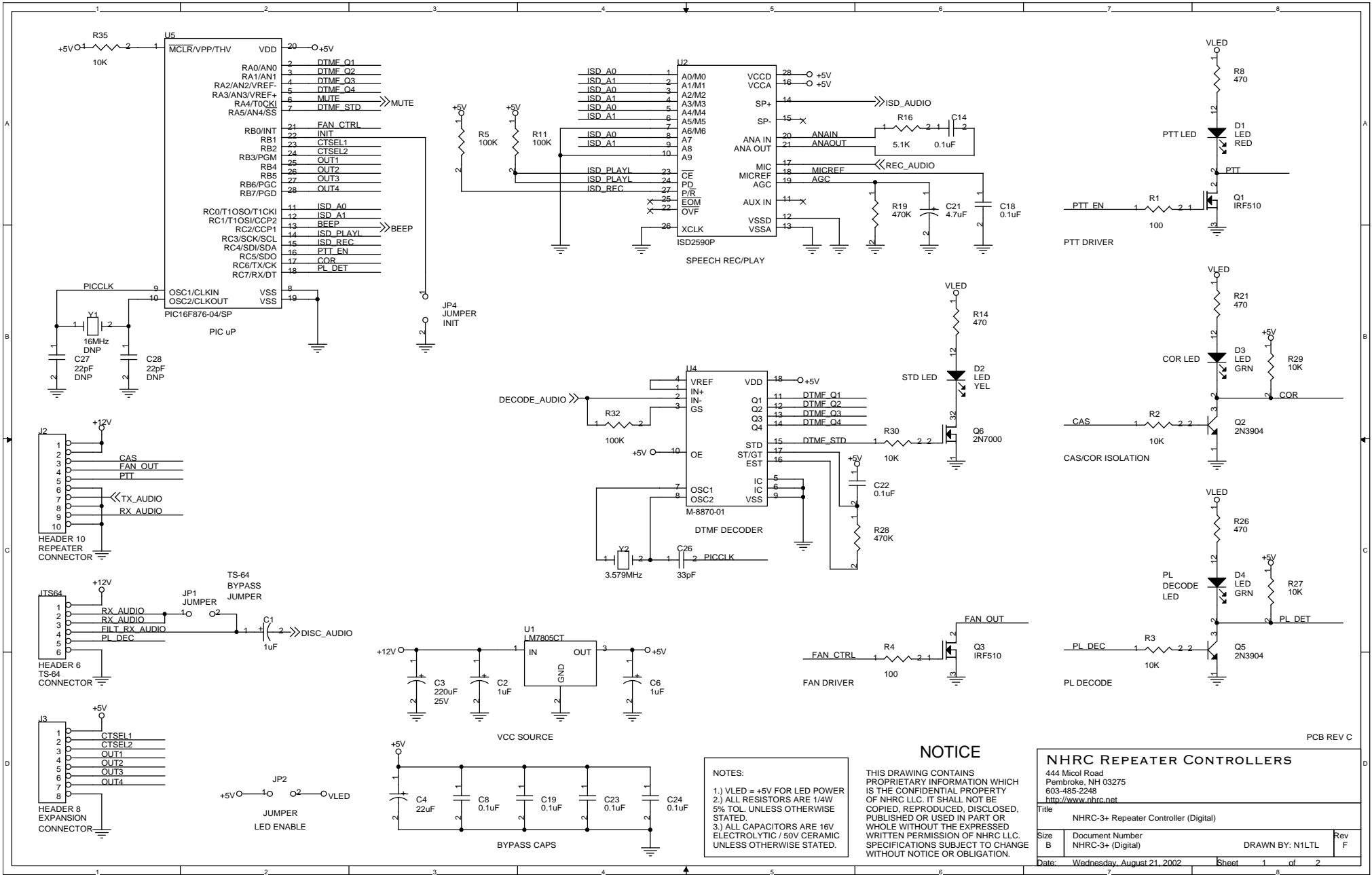

**NOTES:**  
 1.) VLED = +5V FOR LED POWER  
 2.) ALL RESISTORS ARE 1/4W  
 5% TOL UNLESS OTHERWISE STATED.  
 3.) ALL CAPACITORS ARE 16V ELECTROLYTIC / 50V CERAMIC UNLESS OTHERWISE STATED.

**NOTICE**  
 THIS DRAWING CONTAINS PROPRIETARY INFORMATION WHICH IS THE CONFIDENTIAL PROPERTY OF NHRC LLC. IT SHALL NOT BE COPIED, REPRODUCED, DISCLOSED, PUBLISHED OR USED IN PART OR WHOLE WITHOUT THE EXPRESSED WRITTEN PERMISSION OF NHRC LLC. SPECIFICATIONS SUBJECT TO CHANGE WITHOUT NOTICE OR OBLIGATION.

**NHRC REPEATER CONTROLLERS**

444 Micol Road  
 Pembroke, NH 03275  
 603-485-2248  
<http://www.nhrc.net>

Title NHRC-3+ Repeater Controller (Digital)			
Size B	Document Number NHRC-3+ (Digital)	DRAWN BY: N1LTL	Rev F

NOTES:  
 1.) VREF = +6VDC (or 1/2 VDD)  
 2.) ALL RESISTORS ARE 1/4W  
 5% TOL UNLESS OTHERWISE  
 STATED.  
 3.) ALL CAPACITORS ARE 16V  
 ELECTROLYTIC / 50V CERAMIC  
 UNLESS OTHERWISE STATED.

NOTE:  
 JP3 SETTINGS:  
 N JUMPER = NORMAL AUDIO  
 D JUMPER = DE-EMPHASIZED AUDIO  
 NO JUMPER = NORMAL AUDIO W/10X GAIN

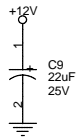
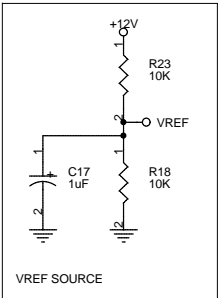
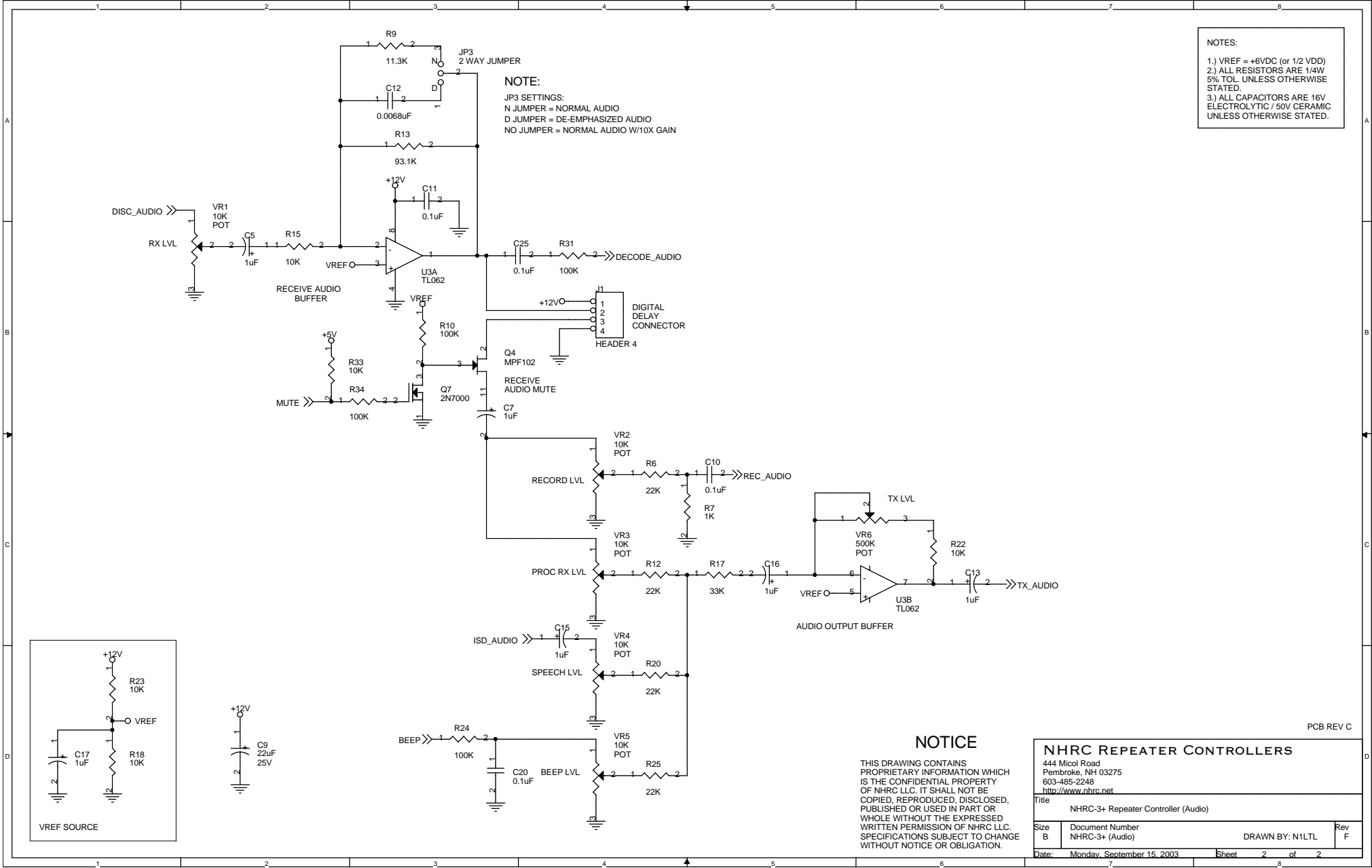

**NOTICE**

THIS DRAWING CONTAINS  
 PROPRIETARY INFORMATION WHICH  
 IS THE CONFIDENTIAL PROPERTY  
 OF NHRC LLC. IT SHALL NOT BE  
 COPIED, REPRODUCED, DISCLOSED,  
 PUBLISHED OR USED IN PART OR  
 WHOLE WITHOUT THE EXPRESSED  
 WRITTEN PERMISSION OF NHRC LLC.  
 SPECIFICATIONS SUBJECT TO CHANGE  
 WITHOUT NOTICE OR OBLIGATION.

<b>NHRC REPEATER CONTROLLERS</b>			
444 Micol Road Pembroke, NH 03275 603-485-2248 <a href="http://www.nhrc.net">http://www.nhrc.net</a>			
Title NHRC-3+ Repeater Controller (Audio)			
Size B	Document Number NHRC-3+ (Audio)	DRAWN BY: N1LTL	Rev F
Date: Monday, September 15, 2003	Sheet 2		of 2

PCB REV C

# NHRC-3+ User Guide

## 9. Parts List

### NHRC-3+ Repeater Controller Parts List

Revised: Wednesday, August 21, 2002  
Revision: B

Item	Qty.	Ref.	Schematic Value	Description	Mfg.	Mfg. P/N
1	9	C1,C2,C5,C6,C7,C13,C15, C16,C17	1uF	1uF 16V Tantalum Cap	Panasonic	ECS-F1CE105K
2	1	C3	220uF	25V 220uF 25V Aluminum Radial Electrolytic Cap	Panasonic	ECA-1EM221
3	1	C4	22uF	22uF 25V Aluminum Radial Electrolytic Cap	Panasonic	ECA-1EM220
4	11	C8,C10,C11,C14,C18,C19, C20,C22,C23,C24,C25	0.1uF	0.1uF 50V Z5U Ceramic Radial Cap	Panasonic	ECU-S1H104MEA
5	1	C9	22uF	25V		
6	1	C12	0.0068uF	0.0068uF 50V X7R Ceramic Radial Cap	Panasonic	ECU-S1H682KBA
7	1	C21	4.7uF			
8	1	C26	33pF	33pF 100V C0G Ceramic Radial Cap	Panasonic	ECU-S2A330JCA
9	2	C27,C28	22pF	DNP 22pF 100V C0G Ceramic Radial Cap	Panasonic	ECU-S2A220JCA
10	1	D1	LED	RED Red T1¼ LED	Lite-On	LTL-4203
11	1	D2	LED	YEL Yellow T1¼ LED	Lite-On	LTL-4253
12	2	D3,D4	LED	GRN Green T1¼ LED	Lite-On	LTL-4234
13	3	JP1,JP2,JP4	JUMPER	2 Circuit Header, .100" Straight	Molex	22-03-2021
14	1	JP3	2 WAY JUMPER	3 Circuit Header, .100" Straight	Molex	22-03-2031
15	1	JTS64	HEADER 6	6 Circuit Header, .100" Straight w/ lock	Molex	22-23-2061
16	1	J1	HEADER 4	4 Circuit Header, .100" Straight w/ lock	Molex	22-23-2041
17	1	J2	HEADER 10	10 Circuit Header, .100" Straight w/ lock	Molex	22-23-2101
18	1	J3	HEADER 8	8 Circuit Header, .100" Straight	Molex	22-03-2081
19	2	Q1,Q3	IRF510	N Channel HEXFET	IRF	IRF510
20	2	Q2,Q5	2N3904	NPN Transistor	Fairchild	2N3904
21	1	Q4	MPF102	N Channel JFET	Fairchild	MPF102
22	2	Q6,Q7	2N7000	N Channel MOSFET	Fairchild	2N7000
23	2	R4,R1	100	100 ¼W 5% Carbon Film Resistor	Yaego	CFR-25JB 100R
24	11	R2,R3,R15,R18,R22,R23, R27,R29,R30,R33,R35	10K	10K ¼W 5% Carbon Film Resistor	Yaego	CFR-25JB 10K
25	7	R5,R10,R11,R24,R31,R32, R34	100K	100K ¼W 5% Carbon Film Resistor	Yaego	CFR-25JB 100K
26	4	R6,R12,R20,R25	22K	22K ¼W 5% Carbon Film Resistor	Yaego	CFR-25JB 22K
27	1	R7	1K	1K ¼W 5% Carbon Film Resistor	Yaego	CFR-25JB 1K0
28	4	R8,R14,R21,R26	470	470 ¼W 5% Carbon Film Resistor	Yaego	CFR-25JB 470R
29	1	R9	11.3K	11.3K ¼W 1% Metal Film Resistor	Yaego	MFR-25FBF 11K3
30	1	R13	93.1K	93.1K ¼W 1% Metal Film Resistor	Yaego	MFR-25FBF 93K1
31	1	R16	5.1K	5.1K ¼W 5% Carbon Film Resistor	Yaego	CFR-25JB 5K1
32	1	R17	33K	33K ¼W 5% Carbon Film Resistor	Yaego	CFR-25JB 33K
33	2	R19,R28	470K	470K ¼W 5% Carbon Film Resistor	Yaego	CFR-25JB 470K
34	1	U1	LM7805CT	5V 1.0A Voltage Regulator	Nat'l Semi	LM340T-5.0
35	1	U2	ISD2590P	90 sec. Voice Recorder/Playback	ISD	ISD2590P
36	1	U3	TL062	Dual JFET Input Op-Amp	TI	TL062CP

## NHRC-3+ User Guide

37	1	U4	M-8870-01	DTMF Decoder	Teltone	M-8870-01
38	1	U5	PIC16F876-04/SP	Microcontroller w/ 8K Flash Memory	Microchip	PIC16F876-04/SP
39	5	VR1,VR2,VR3,VR4,VR5	10K	POT 10K 6mm Carbon Trimpot	Panasonic	EVN-D8AA03B14
40	1	VR6	500K	POT 500K 6mm Carbon Trimpot	Panasonic	EVN-D8AA03B55
41	1	Y1	16MHz	DNP 16MHz Crystal	ECS	ECS-160-20-4
42	1	Y2	3.579MHz	3.579545MHz Crystal	ECS	ECS-35-17-4
<b>Additional Items</b>						
43	1			NHRC-3+ PCB rev C	NHRC	NHRC-3+ PCB rev C
44	1			28 Pin Narrow DIP Socket	Mill-Max	110-99-328-41-001
45	1			28 Pin DIP Socket	Mill-Max	110-99-628-41-001
46	1			8 Pin DIP Socket	Mill-Max	110-99-308-41-001
47	1			18 Pin DIP Socket	Mill-Max	110-99-318-41-001
48	1			10 Circuit Housing, .100" w/ lock and polarizer	Molex	22-01-3107
49	1			6 Circuit Housing, .100" w/ lock and polarizer	Molex	22-01-3067
50	1			4 Circuit Housing, .100" w/ lock and polarizer	Molex	22-01-3047
51	20			Crimp Terminal for Molex Housing	Molex	08-50-0114
52	5			Shorting Jumpers	3M	929950-00-1

### **10. NHRC LLC Limited Warranty**

NHRC LLC warrants that its assembled and tested products will be free from defects in materials and workmanship for a period of NINETY (90) DAYS from the date of shipment. During this period, NHRC LLC will repair or replace, at our option, any of our products that fail as a result of defects in materials or workmanship. NHRC LLC's liability will be limited to parts, labor, and return shipping for this period.

NHRC LLC warrants that its kit products will contain components that are free from defects in materials and workmanship for a period of THIRTY (30) DAYS from the date of shipment. During this period, NHRC will replace any of the components in a kit ONCE. Subsequent replacement of any component any subsequent times is completely at the discretion of NHRC LLC, and may require the complete return of the kit.

In no case will NHRC LLC be liable for products damaged by improper wiring (including, but not limited to, over-voltage or application of reverse polarity), physical damage resulting from misuse and/or abuse of the product, neglect, or acts of God (lightning, floods, etc.).

Unauthorized modification of a NHRC product will void the warranty on the modified product.

In no case will NHRC LLC be liable for any direct, consequential, or incidental loss or damage resulting from the use or inability to use any of its products.

Some states or countries do not allow the limitation of incidental or consequential damages, so the paragraph above may not apply to you.

This warranty applies only to the original purchaser of the product; proof of purchase must be presented to receive warranty service.

**NHRC**  
REPEATER CONTROLLERS